



# **HY13P53B**

## **Datasheet**

8-Bit RISC-like Mixed Signal Microcontroller

Embedded 24-Bit  $\Sigma\Delta$ ADC

## 目錄

1. 特點 .....	4
2. 引腳定義 .....	5
2.1. LQFP64 引腳定義說明 .....	6
2.2. 管腳複用功能 .....	9
3. 應用電路 .....	10
3.1. 帶觸碰按鍵之橋式傳感器 .....	10
4. 功能概述 .....	11
4.1. 內部方塊圖 .....	11
4.2. 相關說明與支援文件 .....	12
4.3. $\Sigma\Delta$ ADC Network .....	13
4.4. Comparator Network .....	13
4.5. $\Sigma\Delta$ ADC Performance .....	14
5. 暫存器列表 .....	17
6. 訂貨資訊 .....	19
7. 封裝型式資訊 .....	20
7.1. LQFP64(L064) .....	20
8. 電氣特性 .....	21
8.1. Recommended operating conditions .....	21
8.2. Internal RC Oscillator .....	21
8.3. Supply current into VDD excluding peripherals current .....	22

# HY13P53B

8-bit RISC-like Mixed Signal Microcontrollers with  
Embedded High Resolution  $\Sigma\Delta$  ADC



8.4. Port1~3.....	22
8.5. Reset(Brownout, External RST pin, Low Voltage Detect).....	23
8.6. Power System .....	24
8.7. LCD .....	24
8.8. Multi-Comparator .....	25
8.9. $\Sigma\Delta$ ADC, Power Supply and Recommended operating conditions.....	26
8.9.1. Operating Current .....	26
8.9.2. Analog Inputs .....	26
8.9.3. Performance .....	27
8.9.4. Voltage Reference .....	27
8.9.5. Temperature sensor .....	28
8.10. Build-In EPROM(BIE).....	28
9. 修訂記錄 .....	29

# HY13P53B

8-bit RISC-like Mixed Signal Microcontrollers with Embedded High Resolution  $\Sigma\Delta$  ADC

## 1. 特點

- 8-Bit RISC-like 微控制器，具有 66 條高性能指令集 H08A
- 串列通訊 EUART 模組
- 24-Bit  $\Sigma\Delta$ ADC 類比數位轉換器
  - 梳狀濾波器採三階設計，轉換頻率高達 31.25Ksps
  - 取樣頻率 125K/250K/500K/1MHz
  - 超取樣頻率設置 32~65535
  - 全差動輸入信號與測量範圍的零點調整
  - 信號放大  $x1, x2 \sim x128$
  - 測量信號輸入通道 7ch
  - 低溫飄係數與內置絕對溫度傳感器
- 內部電源系統
  - 內置 LDO 線性穩壓電源 VDDA
    - ◆ 內部類比電路或外部傳感器電壓源
    - ◆ 輸出可設置 2.4V/2.7V/3.0V/3.3V，可外灌輸入電壓
    - ◆ 低操作功耗與低溫飄係數
  - 內置參考電壓源
    - ◆ 類比電路參考電壓源
    - ◆ 低操作功耗與低溫飄係數
- 多功能比較器
  - 輸出濾波與反相及低功耗設計
  - 中斷事件
  - 電壓檢測/電容測量等應用
- 計時器
  - Watch Dog
    - ◆ 復位事件與中斷事件
  - 8-bit Timer
    - ◆ 中斷事件
  - 16-bit Timer
    - ◆ 16-Bit PWM/PFD 輸出
    - ◆ 8+8 PWM 輸出
    - ◆ 兩個 8-Bit PWM 輸出
    - ◆ 中斷事件

- LCD 驅動顯示器
  - 支援 4x20 點，偏壓模式 1/3
  - 低功耗設計，操作電流 11uA

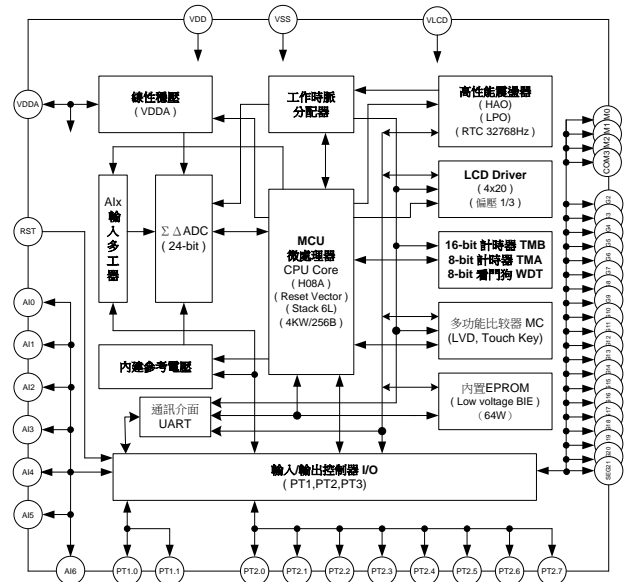

- 工作電壓與操作溫度範圍
  - 2.2V ~ 3.6V, -40°C ~ 85°C
- 工作頻率
  - 僅支援一組外接低速石英震盪器 32768Hz
  - 內建高精度 HAO 震盪器 2MHz/4MHz/7.6MHz
  - 內建低功耗 LPO 震盪器 11.5KHz
- 記憶體型式
  - 4KW OTP 程式記憶體
  - 256B 資料記憶體，6 層堆棧
  - Build-In EPROM
    - ◆ 工作電壓 2.75V
    - ◆ 64W EPROM 記憶體
- 引腳特色
  - 具 10mA 驅動能力
  - 自定義功能模組輸出引腳設計
- 復位機制
  - Power On Reset/Brown Out Reset
  - Watch Dog Reset/Reset PIN

# HY13P53B

8-bit RISC-like Mixed Signal Microcontrollers with  
Embedded High Resolution  $\Sigma\Delta$  ADC

## 2. 引腳定義



圖 2-1 HY13P53B LQFP64 引腳圖

## 2.1. LQFP64 引腳定義說明

“I”：輸入,“O”：輸出,“A”：類比,“S”：史密斯觸發,“C”：CMOS I/O,“\*”：自定義,“/”：或,“X”：可忽略

引腳		設計		描述
編號	名稱/功能	型式	緩衝	
1	RST	I	S	復位引腳
	VPP	P	P	OTP 燒錄電壓引腳
2	PT1.0	I/O	S/C	數位輸入 / 輸出引腳
	INT0	I	S	外部中斷源
	MCH0	A	A	多功能比較器信號輸入引腳
3	PT1.1	I/O	S/C	數位輸入 / 輸出引腳
	INT1	I	S	外部中斷源
	MCH1	A	A	多功能比較器信號輸入引腳
20	SEG21	O	A	LCD 的 SEG.引腳
21	SEG20	O	A	LCD 的 SEG.引腳
22	SEG19	O	A	LCD 的 SEG.引腳
23	SEG18	O	A	LCD 的 SEG.引腳
24	SEG17	O	A	LCD 的 SEG.引腳
25	SEG16	O	A	LCD 的 SEG.引腳
26	SEG15	O	A	LCD 的 SEG.引腳
27	SEG14	O	A	LCD 的 SEG.引腳
28	SEG13	O	A	LCD 的 SEG.引腳
29	SEG12	O	A	LCD 的 SEG.引腳
30	SEG11	O	A	LCD 的 SEG.引腳
31	SEG10	O	A	LCD 的 SEG.引腳
32	SEG9	O	A	LCD 的 SEG.引腳
33	SEG8	O	A	LCD 的 SEG.引腳
34	SEG7	O	A	LCD 的 SEG.引腳
35	SEG6	O	A	LCD 的 SEG.引腳
36	SEG5	O	A	LCD 的 SEG.引腳
37	SEG4	O	A	LCD 的 SEG.引腳
38	SEG3	O	A	LCD 的 SEG.引腳
39	SEG2	O	A	LCD 的 SEG.引腳
40	COM3	O	A	LCD 的 COM 引腳
41	COM2	O	A	LCD 的 COM 引腳
42	COM1	O	A	LCD 的 COM 引腳
43	COM0	O	A	LCD 的 COM 引腳
44	VLCD	P	P	LCD 的電壓源接引腳

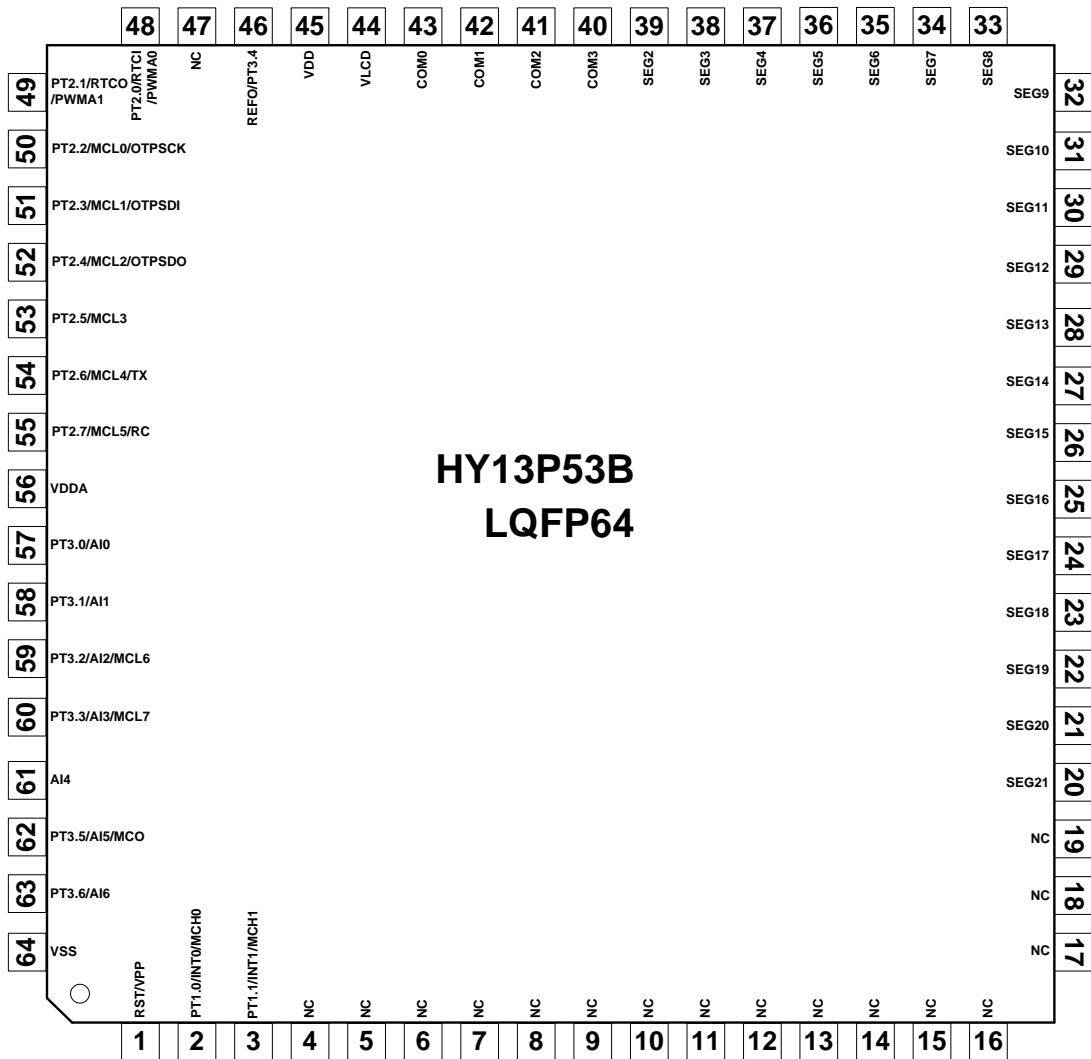
# HY13P53B

8-bit RISC-like Mixed Signal Microcontrollers with  
Embedded High Resolution  $\Sigma\Delta$  ADC

45	VDD	P	P	晶片工作電壓源接引腳
46	PT3.4 REFO	I/O	S/C	數位輸入 / 輸出引腳
		P	P	參考電壓引腳
48	PT2.0 PWMA0 RTCI	I/O	S/C	數位輸入 / 輸出引腳
		O	C	TMB1 的 PWM0 輸出引腳
		A	A	外接 RTC 震盪器引腳
49	PT2.1 PWMA1 RTCO	I/O	S/C	數位輸入 / 輸出引腳
		O	C	TMB1 的 PWM1 輸出引腳
		A	A	外接 RTC 震盪器引腳
50	PT2.2 MCL0 PSCK	I/O	S/C	數位輸入 / 輸出引腳
		A	A	多功能比較器信號輸入引腳
		I	S	OTP 讀/寫介面 PSCK 接口
51	PT2.3 MCL1 PSDI	I/O	S/C	數位輸入 / 輸出引腳
		A	A	多功能比較器信號輸入引腳
		I	S	OTP 讀/寫介面 PSDI 接口
52	PT2.4 MCL2 PSDO	I/O	S/C	數位輸入 / 輸出引腳
		A	A	多功能比較器信號輸入引腳
		O	C	OTP 讀/寫介面 PSDO 接口
53	PT2.5 MCL3	I/O	S/C	數位輸入 / 輸出引腳
		A	A	多功能比較器信號輸入引腳
54	PT2.6 MCL4 TX	I/O	S/C	數位輸入 / 輸出引腳
		A	A	多功能比較器信號輸入引腳
		I	S	EUART 通訊介面 TX 接口
55	PT2.7 MCL5 RC	I/O	S/C	數位輸入 / 輸出引腳
		A	A	多功能比較器信號輸入引腳
		I	S	EUART 通訊介面 RC 接口
56	VDDA	P	P	LDO 線性穩壓電源輸出引腳
57	PT3.0 AI0	I/O	S/C	數位輸入 / 輸出引腳
		A	A	類比輸入通道
58	PT3.1 AI1	I/O	S/C	數位輸入 / 輸出引腳
		A	A	類比輸入通道
59	PT3.2 AI2 MCL6	I/O	S/C	數位輸入 / 輸出引腳
		A	A	類比輸入通道
		A	A	多功能比較器信號輸入引腳
60	PT3.3 AI3 MCL7	I/O	S/C	數位輸入 / 輸出引腳
		A	A	類比輸入通道
		A	A	多功能比較器信號輸入引腳

# HY13P53B

8-bit RISC-like Mixed Signal Microcontrollers with  
Embedded High Resolution  $\Sigma\Delta$  ADC

61	AI4	A	A	類比輸入通道
62	PT3.5	I/O	S/C	數位輸入 / 輸出引腳
		A	A	類比輸入通道
		MCO*	S/C	多功能比較器信號輸出引腳
63	PT3.6	I/O	S/C	數位輸入 / 輸出引腳
		A	A	類比輸入通道
64	VSS	P	P	晶片工作電壓源接地端引腳
Others	NC	--	-	未使用

表 2-1 HY13P53B LQFP64 引腳說明功能概述



# HY13P53B

8-bit RISC-like Mixed Signal Microcontrollers with  
Embedded High Resolution  $\Sigma\Delta$  ADC

## 2.2. 管腳複用功能

Function control bit PIN	Multi-function Comparator				EUART		Timer B	
	No change		MCOO[0]		EUARTO[0]		PWMAO[0]	
			<0>	<1>	<0>	<1>	<0>	<1>
PT1.0		MCH0						
PT1.1		MCH1						
PT2.0							PWMA0	
PT2.1							PWMA1	
PT2.2	MCL0							
PT2.3	MCL1							
PT2.4	MCL2							
PT2.5	MCL3							
PT2.6	MCL4					TX		
PT2.7	MCL5					RC		
PT3.0								
PT3.1								
PT3.2	MCL6							
PT3.3	MCL7							
PT3.4								
PT3.5				MCO*				
PT3.6								

\*\*\* : Not default value;  
Control bit default value: <0>

# HY13P53B

8-bit RISC-like Mixed Signal Microcontrollers with Embedded High Resolution  $\Sigma\Delta$  ADC



## 3. 應用電路

### 3.1. 帶觸碰按鍵之橋式傳感器



圖 3-1 帶觸碰按鍵橋式傳感器應用電路

## 4. 功能概述

### 4.1. 内部方块图

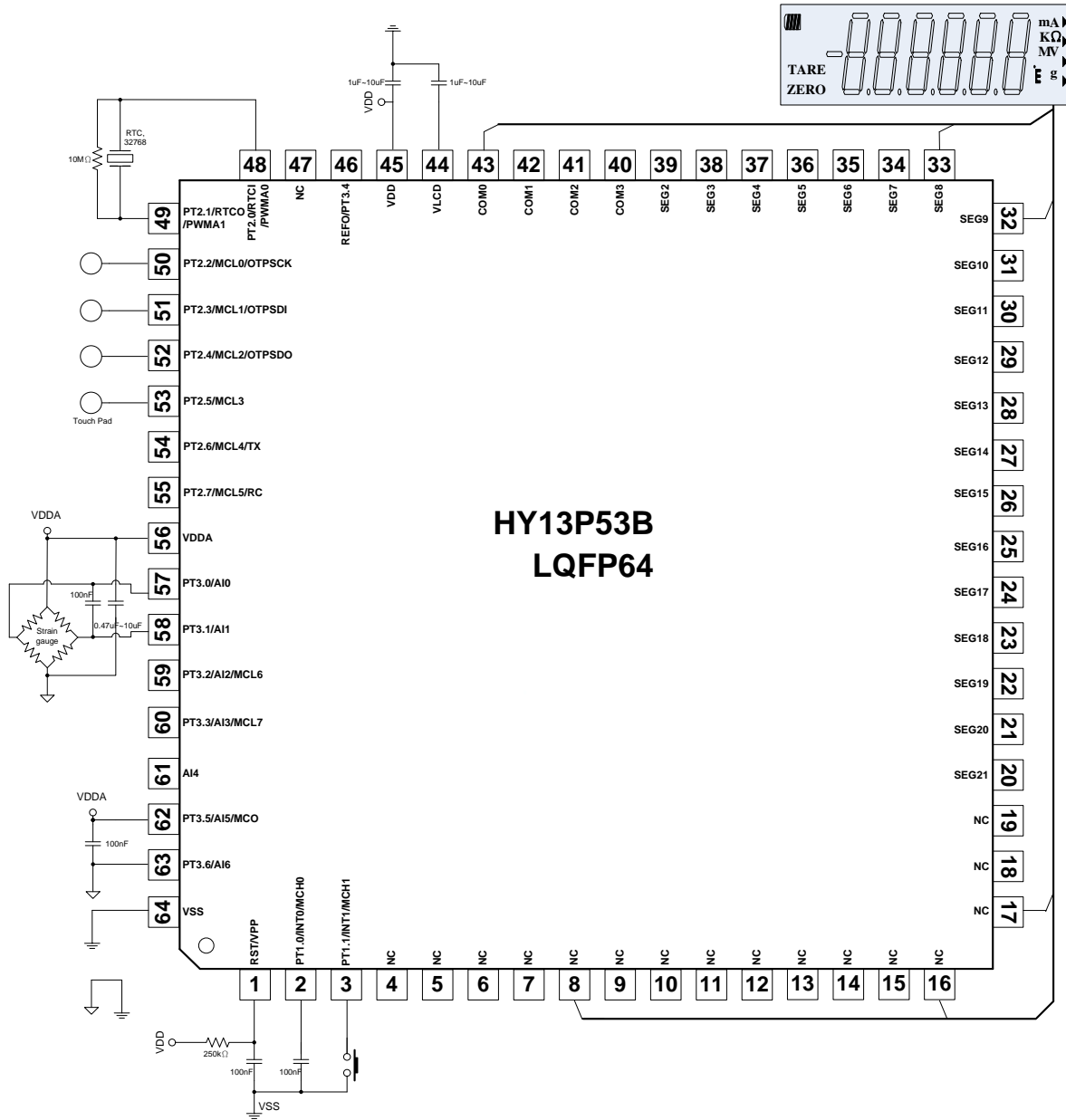

圖 3-1 HY13P53B 内部方块图

## 4.2. 相關說明與支援文件

### 晶片功能相關使用說明書

DS-HY13P53B

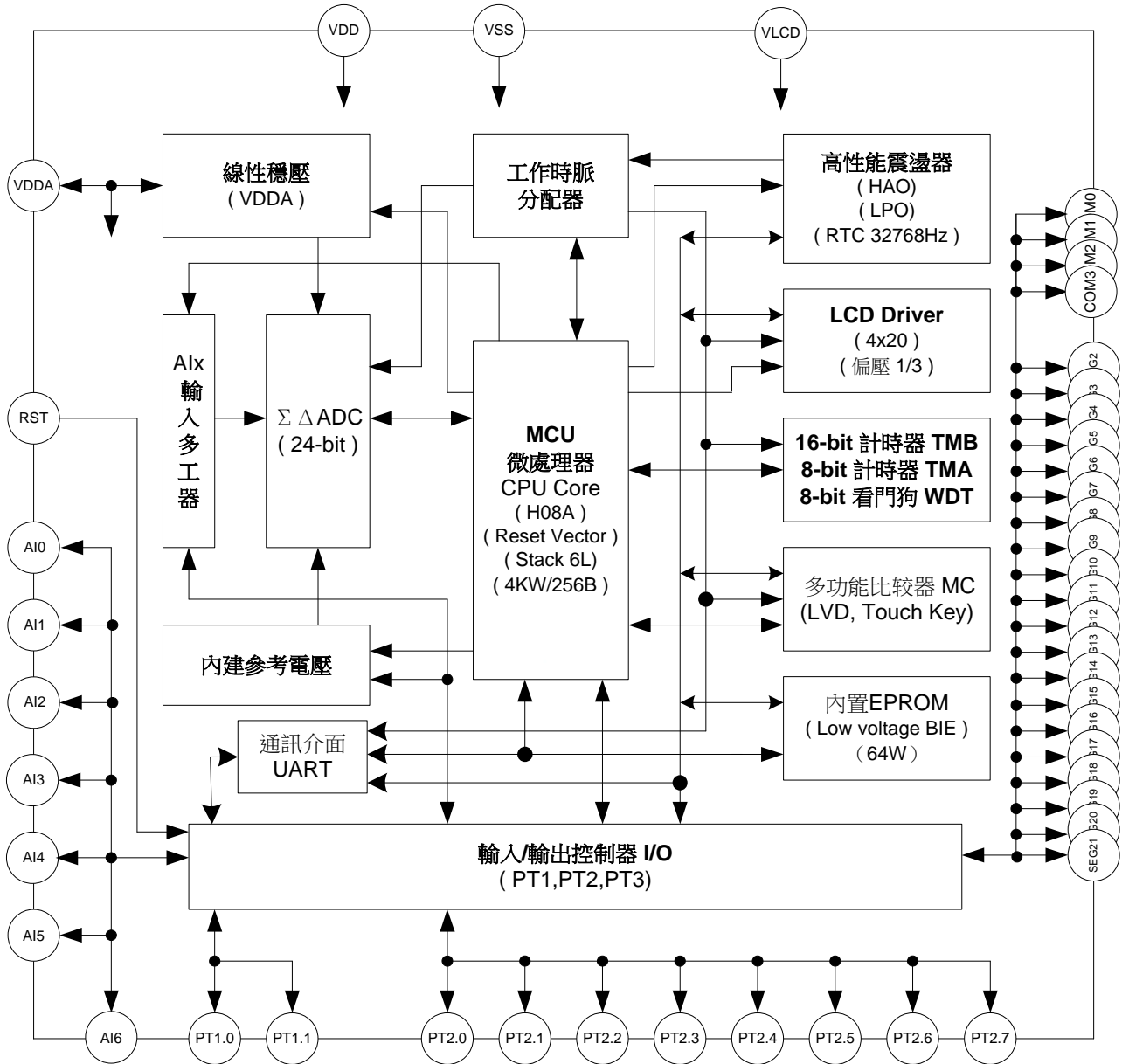
HY13P53B 說明書

UG-HY13S00

HY13Pxx 系列使用說明書

APD-CORE002

H08A 指令說明書

### 開發工具相關使用說明書

APD-HY13PIDE001

HY13Pxx 系列開發工具 ICE 硬體使用說明書

APD-HY13PIDE002

HY13Pxx 系列開發工具 IDE 軟體使用說明書

APD-OTP002

HY13Pxx 系列 OTP 產品燒錄引腳說明書

### 產品生產相關使用說明書

APD-HY13PIDE003

HY13Pxx 系列生產工具 HexLoader 軟體使用說明書

APD-HY13PIDE004

HY13Pxx 系列生產工具燒錄器硬體使用說明書

BDI-HY13P53B

HY13P53B 個別產品的裸片打線資訊

### 4.3. $\Sigma\Delta$ ADC Network

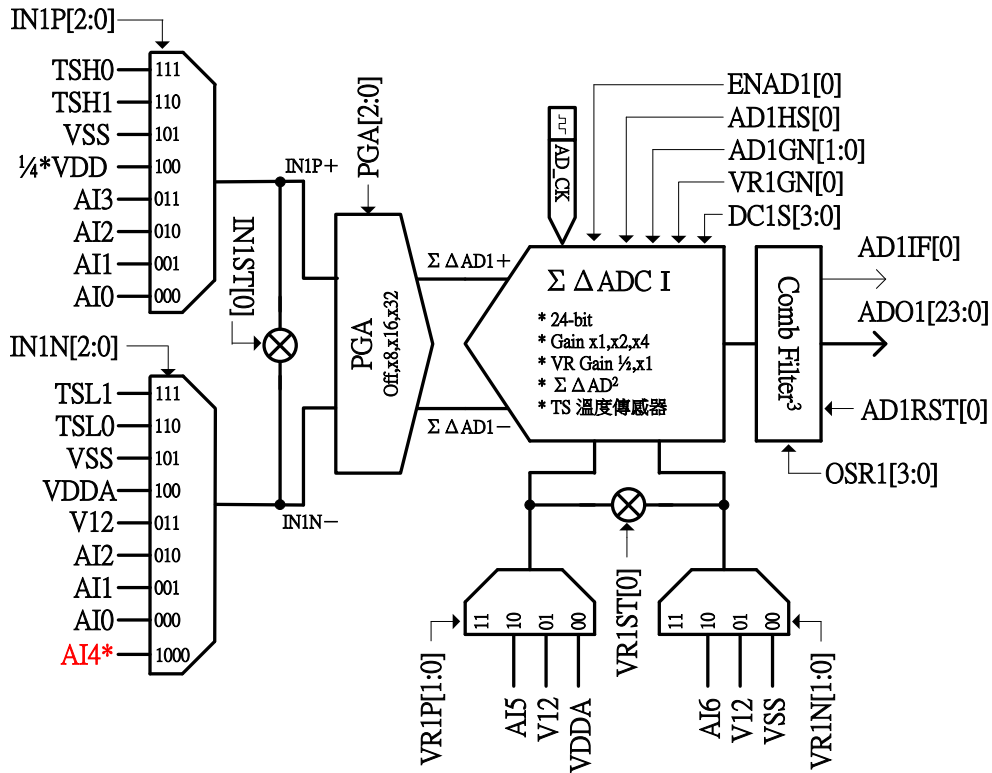

\*Note: [REFOO,IN1N[2:0]]=1000b=AI4 channel

### 4.4. Comparator Network

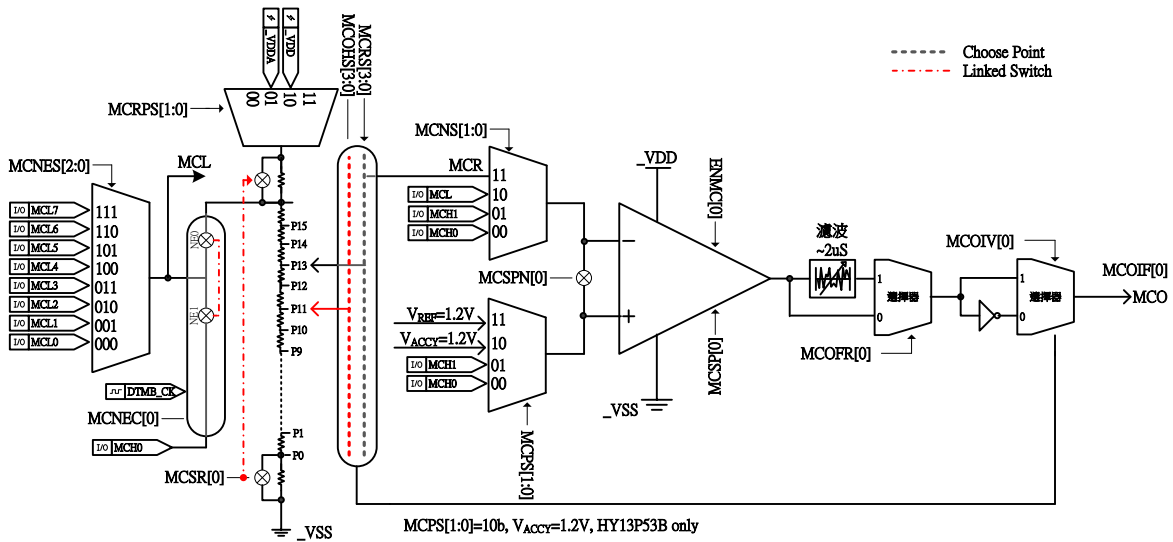

# HY13P53B

8-bit RISC-like Mixed Signal Microcontrollers with Embedded High Resolution  $\Sigma\Delta$  ADC



## 4.5. $\Sigma\Delta$ ADC Performance

$T_A = 25^\circ\text{C}$ ,  $V_{DD} = 3.0\text{V}$ ,  $V_{DDA} = 2.4\text{V}$ , unless otherwise noted

HY13P53B 針對  $\Sigma\Delta$  ADC 提供了重要的輸入雜訊規格。下表列出典型的雜訊規格表與 Gain, Output rate, 及單端最大輸入電壓等關係。測試條件設定在外部輸入訊號短路，參考電壓為 1.2V，取樣 1024 筆資料。

ENOB(RMS) with OSR/GAIN at A/D Clock=1Mhz, VDDA=2.4V, VREF=1.2V																	
Max. Vin(mV) =0.9*VREF (1)	OSR				32	64	128	256	512	1024	2048	4096	8192	16384	32768	65536	
	Output rate(Hz)				31250	15625	7813	3906	1953	977	488	244	122	61	31	15	
	Gain	PGA	x	ADGN													
±1080	1	=	1	x	1	8.6	10.8	13.0	14.7	16.7	17.6	18.1	18.8	19.2	19.7	20.1	20.8
±540	2	=	1	x	2	8.6	10.9	12.8	14.7	16.5	17.5	18.2	18.6	19.0	19.6	20.0	20.6
±270	3	=	1	x	3	8.7	11.0	13.0	14.7	16.5	17.4	18.0	18.5	18.9	19.5	19.8	20.4
±135	4	=	1	x	4	8.6	11.1	12.9	14.7	16.5	17.4	17.9	18.4	18.9	19.3	19.9	20.3
±33.75	32	=	8	x	4	8.6	11.0	12.7	14.2	15.1	15.7	16.3	16.6	17.1	17.6	18.1	18.7
±16.875	64	=	16	x	4	8.6	10.9	12.7	13.9	14.6	15.2	15.7	16.2	16.7	17.3	17.6	18.2
±11.25	96	=	24	x	4	8.6	11.0	12.6	13.8	14.5	15.1	15.5	15.9	16.5	16.9	17.5	18.0
±8.435	128	=	32	x	4	8.6	10.9	12.5	13.6	14.2	14.9	15.2	15.8	16.3	16.9	17.3	17.7

(1) Max. Vin (mV) is the max. input voltage of single end to ground (VSS).

RMS Noise(uV) with OSR/GAIN at A/D Clock=1Mhz, VDDA=2.4V, VREF=1.2V																	
Max. Vin(mV) =0.9*VREF	OSR				32	64	128	256	512	1024	2048	4096	8192	16384	32768	65536	
	Output rate(Hz)				31250	15625	7813	3906	1953	977	488	244	122	61	31	15	
	Gain	PGA	x	ADGN													
±1080	1	=	1	x	1	6208	1317	301	89.6	22.9	12.3	8.34	5.30	4.01	2.91	2.09	1.35
±540	2	=	1	x	2	3067	612	165	45.7	12.6	6.41	4.08	3.01	2.29	1.53	1.11	0.78
±270	3	=	1	x	3	1937	388	99.9	30.3	8.50	4.59	3.13	2.23	1.60	1.07	0.88	0.56
±135	4	=	1	x	4	1508	279	77.3	22.9	6.42	3.57	2.44	1.78	1.27	0.93	0.62	0.47
±33.75	32	=	8	x	4	195	37.4	11.2	3.87	2.18	1.44	0.95	0.76	0.52	0.38	0.27	0.18
±16.875	64	=	16	x	4	97	19.8	5.8	2.49	1.51	0.99	0.71	0.52	0.36	0.23	0.19	0.13
±11.25	96	=	24	x	4	62	12.4	4.2	1.80	1.09	0.74	0.53	0.41	0.26	0.20	0.14	0.10
±8.435	128	=	32	x	4	48	9.6	3.2	1.50	0.99	0.62	0.48	0.32	0.24	0.16	0.12	0.09

ENOB(RMS) with OSR/GAIN at A/D Clock=0.25Mhz, VDDA=2.4V, VREF=1.2V																	
Max. Vin(mV) =0.9*VREF (1)	OSR				32	64	128	256	512	1024	2048	4096	8192	16384	32768	65536	
	Output rate(Hz)				7813	3906	1953	977	488	244	122	61	31	15	8	4	
	Gain	PGA	x	ADGN													
±1080	1	=	1	x	1	8.7	11.0	12.9	14.5	16.4	17.5	18.1	18.7	19.1	19.6	19.8	20.0
±540	2	=	1	x	2	8.7	10.9	13.0	14.7	16.5	17.3	17.9	18.4	19.1	19.5	20.0	20.2
±270	3	=	1	x	3	8.7	11.0	13.0	14.8	16.5	17.3	17.8	18.4	18.9	19.2	19.5	19.4
±135	4	=	1	x	4	8.7	11.1	13.0	14.6	16.4	17.3	17.6	18.3	18.7	19.3	19.7	19.9
±33.75	32	=	8	x	4	8.7	10.8	12.9	14.1	15.2	15.6	16.1	16.6	17.2	17.5	18.1	18.6
±16.875	64	=	16	x	4	8.7	11.0	12.7	13.9	14.8	15.1	15.7	16.1	16.7	17.2	17.8	18.0
±11.25	96	=	24	x	4	8.7	11.0	12.5	13.7	14.4	15.1	15.5	15.9	16.4	17.0	17.5	18.0
±8.435	128	=	32	x	4	8.7	10.9	12.6	13.7	14.3	14.7	15.3	15.8	16.2	16.9	17.2	17.8

RMS Noise(uV) with OSR/GAIN at A/D Clock=0.25Mhz, VDDA=2.4V, VREF=1.2V																	
Max. Vin(mV) =0.9*VREF	OSR				32	64	128	256	512	1024	2048	4096	8192	16384	32768	65536	
	Output rate(Hz)				7813	3906	1953	977	488	244	122	61	31	15	8	4	
	Gain	PGA	x	ADGN													
±1080	1	=	1	x	1	5709	1186	320	102.9	28.8	12.6	8.40	5.80	4.29	2.94	2.67	2.33
±540	2	=	1	x	2	2887	650	151	46.3	13.2	7.54	4.79	3.42	2.21	1.58	1.17	0.97
±270	3	=	1	x	3	1953	401	100.2	29.1	8.85	4.95	3.41	2.39	1.66	1.36	1.12	1.15
±135	4	=	1	x	4	1495	274	75.7	24.5	7.14	3.85	2.94	1.87	1.39	0.96	0.73	0.62
±33.75	32	=	8	x	4	175	41.9	10.1	4.34	2.07	1.48	1.06	0.77	0.48	0.40	0.27	0.19
±16.875	64	=	16	x	4	92	18.1	5.5	2.46	1.30	1.07	0.69	0.52	0.34	0.25	0.17	0.14
±11.25	96	=	24	x	4	59	12.4	4.4	1.90	1.15	0.73	0.53	0.42	0.28	0.19	0.13	0.10
±8.435	128	=	32	x	4	46	9.9	3.1	1.46	0.96	0.70	0.46	0.33	0.24	0.15	0.12	0.08

The RMS noise are referred to the input. The Effective Number of Bits (ENOB(RMS)) is defined as:

$$ENOB(RMS) = \frac{\ln\left(\frac{FSR}{RMS\ Noise}\right)}{\ln(2)}$$

$$RMS\ Noise = \frac{\left(2 \times VREF \times \sqrt{\sum_{k=1}^{1024} (ADO[k] - Average)^2}\right)}{2^{24}}$$

Where FSR (Full - Scale Range) =  $2 \times VREF / Gain$ .

$$Average = \frac{\sum_{k=1}^{1024} (ADO[k])}{1024}$$

RMS Noise Diagram

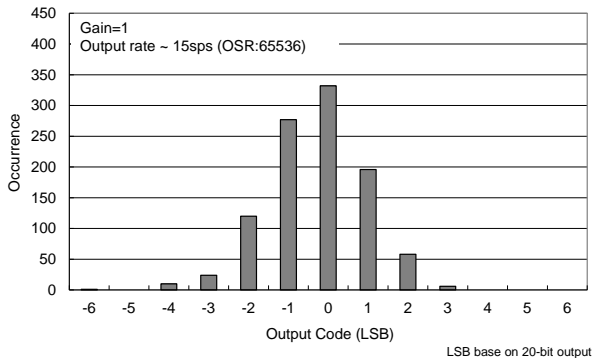

RMS Noise Diagram

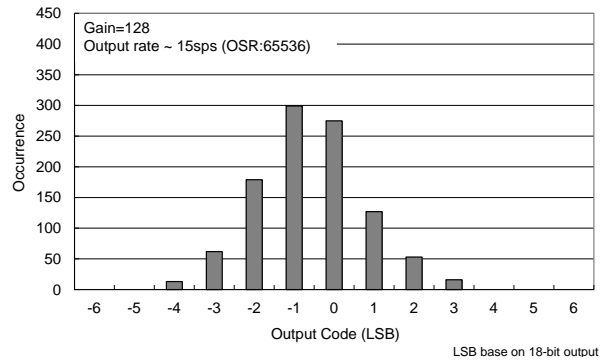

RMS Noise Diagram

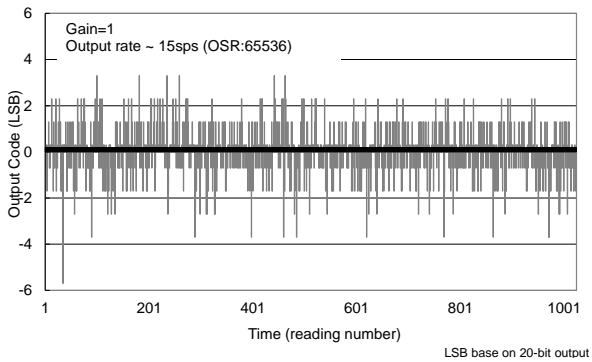

RMS Noise Diagram

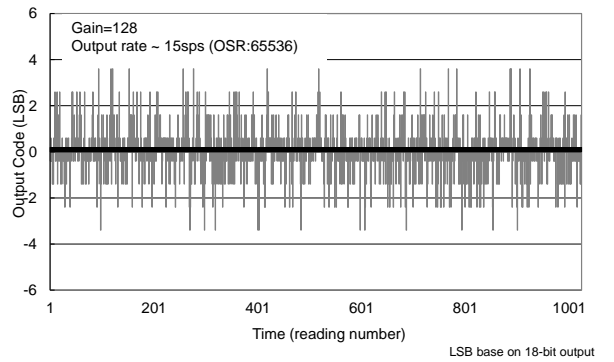

# HY13P53B

8-bit RISC-like Mixed Signal Microcontrollers with Embedded High Resolution  $\Sigma\Delta$  ADC



RMS Noise Diagram

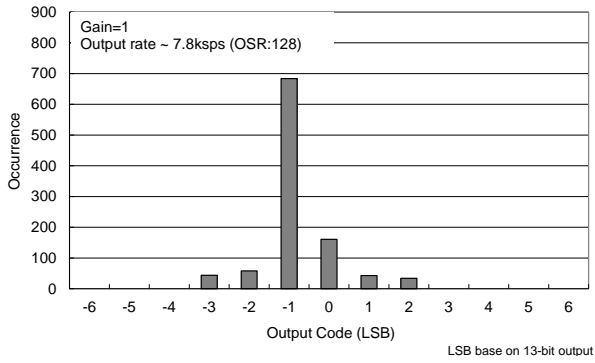

RMS Noise Diagram

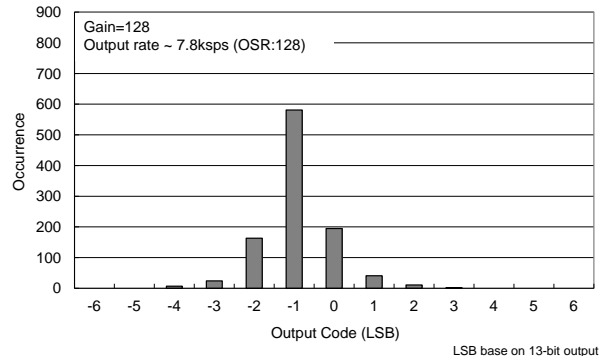

RMS Noise Diagram

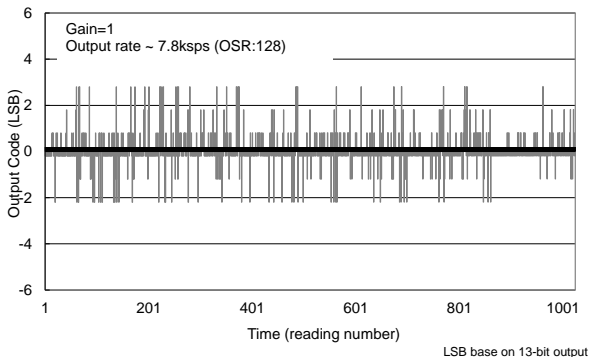

RMS Noise Diagram

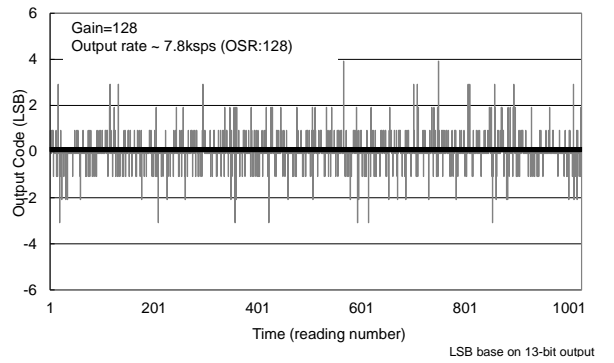





# HY13P53B

## 8-bit RISC-like Mixed Signal Microcontrollers with Embedded High Resolution ΣΔ ADC



Address	Name	Bit 7	Bit 6	Bit 5	Bit 4	Bit 3	Bit 2	Bit 1	Bit 0	ARST	IRST	irst-wdt	irst-skerr	INT	R/W	
059h	UR0CN	ENSP	ENTX	TX9	TX9D	PARITY			WUE	0000 0..0	uuuu u..u	uuuu u..u	uuuu u..u	uuuu uuuu	*****	
05Ah	UR0STA		RC9D	PERR	FERR	OERR	RCIDL	TRMT	ABDOVF	.000 0010	.uuu uuuu	.uuu uuuu	.uuu uuuu	uuuu u\$Su	~.r.r.r.r.r.r.r.r.W0	
05Bh	BA0CN					ENCR	RC9	ENADD	ENABD	.... 0000	.... uuuu	.... uuuu	.... uuuu	uuuu uuuu	*****	
05Ch	BG0RH	Baud Rate Generator Register High Byte								...X xxxx	...U uuuu	...U uuuu	...U uuuu	...U uuuu	*****	
05Dh	BG0RL	Baud Rate Generator Register Low Byte								xxxx xxxx	uuuu uuuu	uuuu uuuu	uuuu uuuu	uuuu uuuu	*****	
05Eh	TX0R	UART Transmit Register								xxxx xxxx	uuuu uuuu	uuuu uuuu	uuuu uuuu	uuuu uuuu	*****	
05Fh	RCREG	UART Receive Register								xxxx xxxx	uuuu uuuu	uuuu uuuu	uuuu uuuu	uuuu uuuu	r.r.r.r.r.r.r.r	
070h	PT1							PT11	PT10	.... .xx	.... .xx	.... .xx	.... .xx	.... .\$\$	*****	
071h	TRISC1							TC11	TC10	.... .00	.... .uu	.... .uu	.... .uu	.... .uu	*****	
072h	PT1DA					FMCO		DA11	DA10	.... 0.00	.... U.uu	.... U.uu	.... U.uu	.... U.uu	*****	
073h	PT1PU							PU11	PU10	.... .00	.... .uu	.... .uu	.... .uu	.... .uu	*****	
074h	PT1EG					E1EG[1:0]		E0EG[1:0]		.... 0000	.... uuuu	.... uuuu	.... uuuu	.... uuuu	*****	
075h	PT2	PT27	PT26	PT25	PT24	PT23	PT22	PT21	PT20	xxxx xxxx	xxxx xxxx	xxxx xxxx	xxxx xxxx	uuuu uuuu	*****	
076h	TRISC2	TC27	TC26	TC25	TC24	TC23	TC22	TC21	TC20	0000 0000	uuuu uuuu	uuuu uuuu	uuuu uuuu	uuuu uuuu	*****	
077h	PT2DA	DA27	DA26	DA25	DA24	DA23	DA22	FPWMA1	FPWMA0	0000 0000	uuuu uuuu	uuuu uuuu	uuuu uuuu	uuuu uuuu	*****	
078h	PT2PU	PU27	PU26	PU25	PU24	PU23	PU22	PU21	PU20	0000 0000	uuuu uuuu	uuuu uuuu	uuuu uuuu	uuuu uuuu	*****	
079h	PT3	PT37	PT36	PT35	PT34	PT33	PT32	PT31	PT30	xxxx xxxx	xxxx xxxx	xxxx xxxx	xxxx xxxx	uuuu uuuu	*****	
07Ah	TRISC3		TC36	TC35	TC34	TC33	TC32	TC31	TC30	.000 0000	.uuu uuuu	.uuu uuuu	.uuu uuuu	.uuu uuuu	*****	
07Bh	PT3DA		DA36	DA35	DA34	DA33	DA32	DA31	DA30	.000 0000	.uuu uuuu	.uuu uuuu	.uuu uuuu	.uuu uuuu	*****	
07Ch	PT3PU		PU36	PU35	PU34	PU33	PU32	PU31	PU30	.000 0000	.uuu uuuu	.uuu uuuu	.uuu uuuu	.uuu uuuu	*****	
080h ~ 017Fh	General Purpose Register as 256Byte									uuuu uuuu	uuuu uuuu	uuuu uuuu	uuuu uuuu	uuuu uuuu	*****	
180h	LCDCN1	ENLCD	LCDPR	VLCD[1:0]			LCDBF				0000 00..	uuuu uu..	uuuu uu..	uuuu uu..	uuuu uu..	*****
181h	LCDCN2	LCDBL	LCDMX[1:0]			LCDS	DLCD[1:0]				0000 00..	uuuu uu..	uuuu uu..	uuuu uu..	uuuu uu..	*****
182h	LCD0	Segment SEG2@[3:0] and SEG3@[7:4] data register of LCD									xxxx xxxx	uuuu uuuu	uuuu uuuu	uuuu uuuu	uuuu uuuu	*****
183h	LCD1	Segment SEG4@[3:0] and SEG5@[7:4] data register of LCD									xxxx xxxx	uuuu uuuu	uuuu uuuu	uuuu uuuu	uuuu uuuu	*****
184h	LCD2	Segment SEG6@[3:0] and SEG7@[7:4] data register of LCD									xxxx xxxx	uuuu uuuu	uuuu uuuu	uuuu uuuu	uuuu uuuu	*****
185h	LCD3	Segment SEG8@[3:0] and SEG9@[7:4] data register of LCD									xxxx xxxx	uuuu uuuu	uuuu uuuu	uuuu uuuu	uuuu uuuu	*****
186h	LCD4	Segment SEG10@[3:0] and SEG11@[7:4] data register of LCD									xxxx xxxx	uuuu uuuu	uuuu uuuu	uuuu uuuu	uuuu uuuu	*****
187h	LCD5	Segment SEG12@[3:0] and SEG13@[7:4] data register of LCD									xxxx xxxx	uuuu uuuu	uuuu uuuu	uuuu uuuu	uuuu uuuu	*****
188h	LCD6	Segment SEG14@[3:0] and SEG15@[7:4] data register of LCD									xxxx xxxx	uuuu uuuu	uuuu uuuu	uuuu uuuu	uuuu uuuu	*****
189h	LCD7	Segment SEG16@[3:0] and SEG17@[7:4] data register of LCD									xxxx xxxx	uuuu uuuu	uuuu uuuu	uuuu uuuu	uuuu uuuu	*****
18Ah	LCD8	Segment SEG18@[3:0] and SEG19@[7:4] data register of LCD									xxxx xxxx	uuuu uuuu	uuuu uuuu	uuuu uuuu	uuuu uuuu	*****
18Bh	LCD9	Segment SEG20@[3:0] and SEG21@[7:4] data register of LCD									xxxx xxxx	uuuu uuuu	uuuu uuuu	uuuu uuuu	uuuu uuuu	*****

## 6. 訂貨資訊

下單品名 <sup>1</sup>	封裝型式	引腳數	封裝型式		程式碼	出貨包裝 形式	個裝 數量	材料 組成	MSL <sup>3</sup>
			描述方式	編號 <sup>2</sup>					
HY13P53B-D000	Die	-	D	000	000	-	200	Green <sup>4</sup>	-
HY13P53B-L064	LQFP	64	L	064	000	Tray	250	Green <sup>4</sup>	MSL-3

<sup>1</sup> 產品名稱 – 封裝型式描述方式 – 程式碼編號（空白片 / 標準品 / 代客燒錄碼）

例如：您的需求是不帶程式碼的空白片且需要的產品是裸片出貨，晶片型號為 HY13P53B。則下單品名為 HY13P53B-D000

例如：您的代客燒錄服務申請的程式碼編號為 008，晶片型號為 HY13P53B，且需要的產品是裸片出貨。則下單品名為 HY13P53B-D000-008

例如：您的需求是晶片型號為 HY13P53B，不帶程式碼的空白片且需要的產品是封裝片 LQFP64 出貨，則下單品名為 HY13P53B-L064，且需以 Tray 出貨，則除下單品名外，請特別註明出貨包裝形式為 Tray

例如：您的需求是晶片型號為 HY13P53B，代客燒錄服務申請的程式碼編號為 009，而需求的產品是封裝片 LQFP64 出貨，則下單品名為 HY13P53B-L064-009，且需以 Tray 出貨，則除下單品名外，請特別註明出貨包裝形式為 Tray

<sup>2</sup> 程式碼編號

“001”~“999” 為標準品或代客燒錄申請的程式碼編號，而空白晶片不帶此碼。

<sup>3</sup> MSL:

濕度敏感性等級係依據 IPC/JEDEC J-STD-020 的規範加以試驗分級，並參考 IPC/JEDEC J-STD-033 的標準處理、包裝、運輸與使用。

<sup>4</sup> Green (RoHS & no Cl/Br):

HYCON 產品皆為 Green Product，符合 RoHS 指令以及無鹵素規定(Br/Cl<0.1%)

# HY13P53B

8-bit RISC-like Mixed Signal Microcontrollers with Embedded High Resolution  $\Sigma\Delta$  ADC

## 7. 封裝型式資訊

### 7.1. LQFP64(L064)

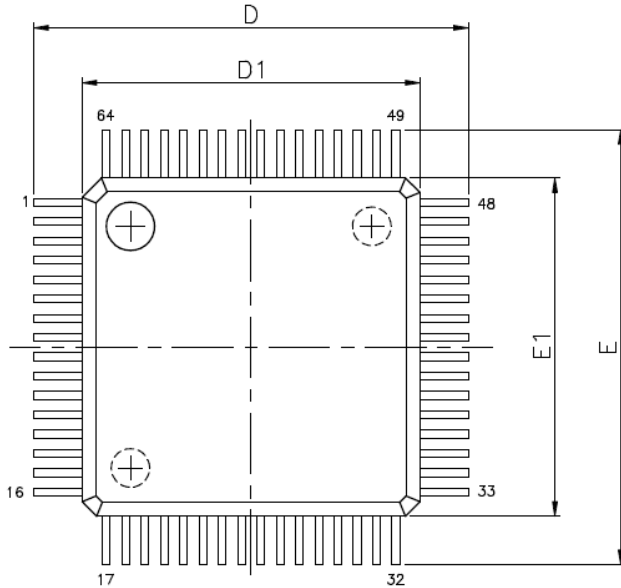

VARIATIONS (ALL DIMENSIONS SHOWN IN MM)

SYMBOLS	MIN.	NOM.	MAX.
A	—	—	1.60
A1	0.05	—	0.15
A2	1.35	1.40	1.45
b	0.13	0.18	0.23
c	0.09	—	0.20
D	9.00 BSC		
D1	7.00 BSC		
e	0.40 BSC		
E	9.00 BSC		
E1	7.00 BSC		
L	0.45	0.60	0.75
L1	1.00 REF		
$\theta$	0°	3.5°	7°

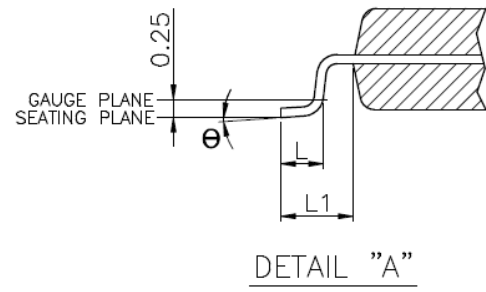
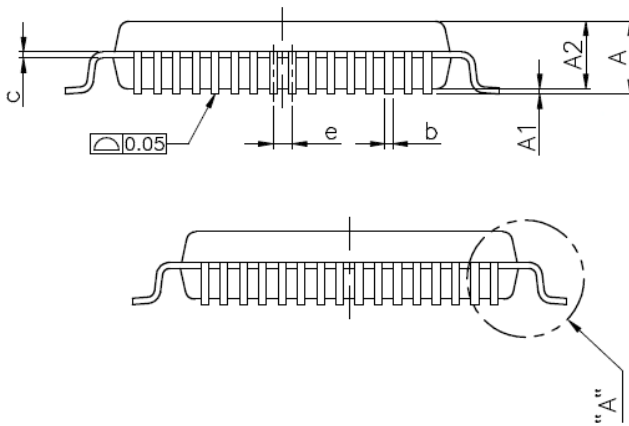

JEDEC MS-026 compliant

# HY13P53B

8-bit RISC-like Mixed Signal Microcontrollers with  
Embedded High Resolution  $\Sigma\Delta$  ADC



## 8. 電氣特性

**Absolute maximum ratings over operating free-air temperature (unless otherwise noted)**

Voltage applied at $V_{DD}$ to $V_{SS}$ .....	-0.2 V to 4.0 V
Voltage applied to any pin (see Note 1) .....	-0.2 V to $V_{DD} + 0.3$ V
Voltage applied to RST/VPP pin .....	-0.2 V to 6.9 V
Voltage applied to TST pin (see Note 1) .....	-0.2 V to $V_{DD} + 1V$
Diode current at any device terminal .....	$\pm 2$ mA
Storage temperature, Tstg: (unprogrammed device) .....	-55°C to 150°C
(programmed device) .....	-40°C to 85°C
Total power dissipation .....	0.5w
Maximum output current sink by any PORT1 to PORT3 I/O pin .....	.25mA

### 8.1. Recommended operating conditions

$T_A = -40^\circ\text{C} \sim 85^\circ\text{C}$ , unless otherwise noted

Sym.	Parameter	Test Conditions	Min.	Typ.	Max.	unit
$V_{DD}$	Supply Voltage	All digital peripherals and CPU	2.2		3.6	V
		Analog peripherals	2.4		3.6	
$V_{SS}$	Supply Voltage		0		0	
RTC	External Oscillator Frequency	$V_{DD} = 2.2V, ENRTC[0]=1$		32.768K		HZ

### 8.2. Internal RC Oscillator

$T_A = 25^\circ\text{C}, V_{DD} = 3.0V$ , unless otherwise noted

Sym.	Parameter	Test Conditions	Min.	Typ.	Max.	unit
IRCH	High Speed Oscillator frequency	ENHAO[0]=1, HAOM[1:0]=00b		2.0		MHz
		ENHAO[0]=1, HAOM[1:0]=01b		4.0		MHz
		ENHAO[0]=1, HAOM[1:0]=11b		7.6		MHz
IRCL	Low Power Oscillator frequency			11.5		KHz

## 8.3. Supply current into VDD excluding peripherals current

$T_A = 25^\circ\text{C}, V_{DD} = 3.0\text{V}, \text{OSC\_LPO} = 11\text{KHz}$ , unless otherwise noted

Sym.	Parameter	Test Conditions	Min.	Typ.	Max.	unit
$I_{AM1}$	Active mode 1	OSC_CY = off, OSC_HAO = 7.6MHz, CPU_CK = 7.6MHz		0.9	2	mA
$I_{AM2}$	Active mode 2	OSC_CY = off, OSC_HAO = 4MHz, CPU_CK = 4MHz		0.5	1	mA
$I_{AM3}$	Active mode 3	OSC_CY = off, OSC_HAO = 2MHz, CPU_CK = 2MHz		0.27	0.5	mA
$I_{AM4}$	Active mode 4	OSC_CY = off, OSC_HAO = 2MHz, CPU_CK = 1MHz		0.15	0.3	mA
$I_{LP1}$	Low Power 1	OSC_CY = 32768Hz, OSC_HAO = off, CPU_CK = 32768Hz		7	12	uA
$I_{LP2}$	Low Power 2	OSC_CY = 32768Hz, OSC_HAO = off, CPU_CK = 16384Hz		5	10	uA
$I_{LP3}$	Low Power 3	OSC_CY = off, OSC_HAO = off, CPU_CK = LPO, Idle state		2	4	uA
$I_{LP4}$	Low Power 4	Sleep state		0.6	1	uA

OSC\_CY : External Oscillator frequency.

OSC\_HAO : Internal High Accuracy Oscillator frequency.

CPU\_CK : CPU core work frequency.

## 8.4. Port1~3

$T_A = 25^\circ\text{C}, V_{DD} = 3.0\text{V}$ , unless otherwise noted

Sym.	Parameter	Test Conditions	Min.	Typ.	Max.	unit
<b>Input voltage and Schmitt trigger and leakage current and timing</b>						
$V_{IH}$	High-Level input voltage				2.1	V
$V_{IL}$	Low-Level input voltage		0.9			
$V_{hys}$	Input Voltage hysteresis( $V_{IH} - V_{IL}$ )			0.8		V
$I_{LKG}$	Leakage Current				0.1	uA
$R_{PU}$	Port pull high resistance			200		k $\Omega$
<b>Output voltage and current and frequency</b>						
$V_{OH}$	High-level output voltage	$I_{OH}=10\text{mA}$	$V_{DD} - 0.3$			V
$V_{OL}$	Low-level output voltage	$I_{OL}=-10\text{mA}$		$V_{SS} + 0.3$		

## 8.5. Reset(Brownout, External RST pin, Low Voltage Detect)

$T_A = 25^\circ\text{C}, V_{DD} = 3.0\text{V}$ , unless otherwise noted

Sym.	Parameter	Test Conditions	Min.	Typ.	Max.	unit
BOR	Pulse length needed to accepted reset internally, $t_{d-LVR}$		2			us
	$V_{DD}$ Start Voltage to accepted reset internally (L $\rightarrow$ H), $V_{LVR}$		1.8	1.9	2.0	V
	Hysteresis, $V_{HYS-LVR}$			35		mV
RST	Pulse length needed as RST/VPP pin to accepted reset internally, $t_{d-RST}$		2			us
	Input Voltage to accepted reset internally		0.9			V
	Hysteresis, $V_{HYS-RST}$			0.8		V

BOR : Brownout Reset. LVR : Low Voltage Reset of BOR. RST : External Reset pin

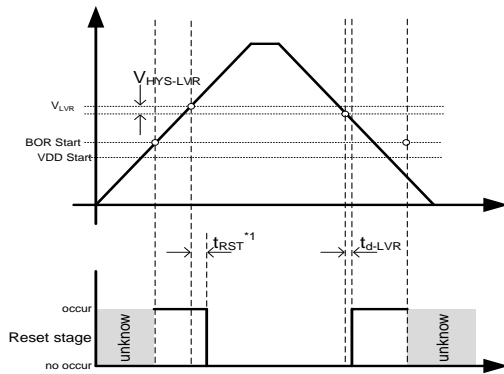

Figure BOR reset diagram

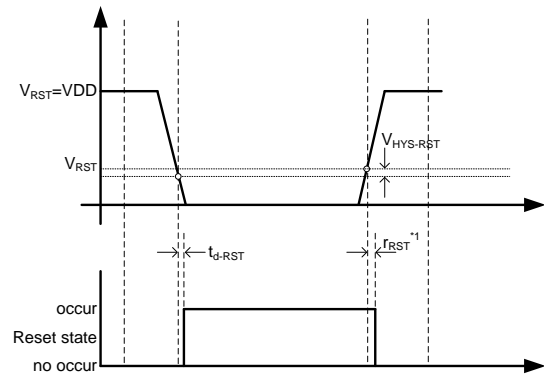

Figure RST reset diagram

## 8.6. Power System

$T_A = 25^\circ\text{C}, V_{DD} = 3.0\text{V}$ , unless otherwise noted

Sym.	Parameter	Test Conditions		Min.	Typ.	Max.	unit
VDDA	VDDA operation current, $I_{VDDA}$	$I_L = 0\text{mA}$	ENLDO[1:0]=11b		11		$\mu\text{A}$
	Select VDDA output voltage	$I_L = 0.1\text{mA}$ , $V_{DD} \geq V_{DDA} + 0.2\text{V}$	VDDAX[1:0]=00b		2.4		V
			VDDAX[1:0]=01b		2.7		V
			VDDAX[1:0]=10b		3.0		V
			VDDAX[1:0]=11b		3.3		V
	Dropout voltage	$I_L = 10\text{mA}$	VDDAX[2:0]=00b		120		mV
			VDDAX[2:0]=01b		130		mV
			VDDAX[2:0]=10b		140		mV
			VDDAX[2:0]=11b		160		mV
	Temperature drift	VDDX[1:0]=11b	$T_A = -40^\circ\text{C} \sim 85^\circ\text{C}$		50		ppm/ $^\circ\text{C}$
$V_{DD}$ Voltage drift	$I_L = 0.1\text{mA}$	$V_{DD} = 2.5\text{V} \sim 3.6\text{V}$		$\pm 0.2$		%/V	
REFO	REFO operation current, $I_{REFO}$	$I_L = 0\text{mA}$			20		$\mu\text{A}$
	Output voltage, $V_{REFO}$	ENREFO[0]=1	$I_L = 0\mu\text{A}$		1.2		V
	Output voltage with Load		$I_L = \pm 200\mu\text{A}$	0.98		1.02	$V_{ACM}$
	Temperature drift	ENREFO[0]=1,	$T_A = -40^\circ\text{C} \sim 85^\circ\text{C}$		50		ppm/ $^\circ\text{C}$
	VDDA Voltage drift	$I_L = 10\mu\text{A}$			150		$\mu\text{V}/\text{V}$
VDDA : Adjust Voltage Regulator							
REFO : Reference Voltage							

## 8.7. LCD

$T_A = 25^\circ\text{C}, V_{DD} = 3.0\text{V}, C_{VLCD} = 1\mu\text{F}$ , unless otherwise noted.

Sym.	Parameter	Test Conditions		Min.	Typ.	Max.	unit
$I_{LCD}$	Operation supply current without output buffer.	LCDPR[0]=1	$V_{DD} = 2.2\text{V}$	11			$\mu\text{A}$
			$V_{DD} = 3.0\text{V}$				
VLCD	Supply Voltage at VLCD pin	LCDPR[0]=0		2.2		3.6	V
	Embedded Charge Pump output voltage at VLCD pin	$V_{DD} = 2.2\text{V}$ , LCDPR[0]=1, $C_{VLCD} = 1\mu\text{F}$	VLCDX[1:0]=11b	-10%	2.55	+10%	V
			VLCDX[1:0]=10b	-10%	2.75	+10%	
			VLCDX[1:0]=01b	-10%	2.95	+10%	
		VLCDX[1:0]=00b	-10%	3.25	+10%		
$Z_{LCD}$	Output impedance with LCD buffer	$f_{LCD} = 178\text{Hz}, VLCD = 2.9\text{V}$			10		k $\Omega$



## 8.8. Multi-Comparator

$T_A = 25^\circ\text{C}, V_{DD} = 3.0\text{V}$ , unless otherwise noted.

Sym.	Parameter	Test Conditions	Min.	Typ.	Max.	unit
$I_{MC}$	Operation supply current	ENMC[0]=1, MCLP[0]=1b	5			uA
	Low Power Mode	ENMC[0]=1, MCLP[0]=0b	1			
$V_{IC}$	Common-mode input voltage		0		$V_{DD}-1$	V
$V_{OS}$	Offset voltage		-5		5	mV
$V_{hys}$	Input hysteresis		0	0.7	1.5	mV
$V_{REF}$	Reference Voltage	MCPS[1:0]=11b	1.1	1.2	1.3	V
	Temperature Drift	MCPS[1:0]=11b	50			ppm/ $^\circ\text{C}$
	VDD Voltage drift	MCPS[1:0]=11b	$\pm 2$			%/V
$V_{ACCY}$	Reference Voltage	ENLDO[1:0]=11b, MCPS[1:0]=10b	1.15	1.2	1.25	V
	Temperature Drift	ENLDO[1:0]=11b, MCPS[1:0]=10b	50			ppm/ $^\circ\text{C}$
	VDD Voltage drift	ENLDO[1:0]=11b, MCPS[1:0]=10b	$\pm 0.2$			%/V
$I_R$	Multi-node resistor current	MCSR[0]=0b	10			uA
		MCSR[0]=1b	30			
LVD	ENLDO[1:0]=11b, MCPS[1:0]=11b, MCSR[0]=0b, MCRS[3:0]=0011b		-0.1	3.2	+0.1	V
	ENLDO[1:0]=11b, MCPS[1:0]=11b, MCSR[0]=0b, MCRS[3:0]=0100b		-0.1	3.0	+0.1	
	ENLDO[1:0]=11b, MCPS[1:0]=11b, MCSR[0]=0b, MCRS[3:0]=0101b		-0.1	2.9	+0.1	
	ENLDO[1:0]=11b, MCPS[1:0]=11b, MCSR[0]=0b, MCRS[3:0]=0110b		-0.1	2.7	+0.1	
	ENLDO[1:0]=11b, MCPS[1:0]=11b, MCSR[0]=0b, MCRS[3:0]=0111b		-0.1	2.6	+0.1	
	ENLDO[1:0]=11b, MCPS[1:0]=11b, MCSR[0]=0b, MCRS[3:0]=1000b		-0.1	2.5	+0.1	
	ENLDO[1:0]=11b, MCPS[1:0]=11b, MCSR[0]=0b, MCRS[3:0]=1001b		-0.1	2.4	+0.1	
	ENLDO[1:0]=11b, MCPS[1:0]=11b, MCSR[0]=0b, MCRS[3:0]=1010b		-0.1	2.3	+0.1	
	ENLDO[1:0]=11b, MCPS[1:0]=11b, MCSR[0]=0b, MCRS[3:0]=1011b		-0.1	2.2	+0.1	
	ENLDO[1:0]=11b, MCPS[1:0]=11b, MCSR[0]=0b, MCRS[3:0]=1100b		-0.1	2.1	+0.1	
	ENLDO[1:0]=11b, MCPS[1:0]=11b, MCSR[0]=0b, MCRS[3:0]=1101b		-0.1	2.0	+0.1	
	MCRS[3:0]=0000b~0010b, and 1110b~1111b (reserved)		-			

LVD : Low Voltage Detect. Note : 當 MCPS[1:0]= 11b 的時候, 代表選擇到  $V_{REF}$ , 則 LVD 上下限規格為 0.1V. 而當 MCPS[1:0]= 10b 的時候, 代表選擇到  $V_{ACCY}$ , 則 LVD 上下限規格為 0.05V

# HY13P53B

8-bit RISC-like Mixed Signal Microcontrollers with  
Embedded High Resolution  $\Sigma\Delta$  ADC



## 8.9. $\Sigma\Delta$ ADC, Power Supply and Recommended operating conditions

$T_A = 25^\circ\text{C}, V_{DD} = 3.0\text{V}, V_{DDA}=2.4\text{V}$ , unless otherwise noted

Sym.	Parameter	Test Conditions	Min.	Typ.	Max.	unit
$V_{SD18}$	Supply Voltage at VDDA		2.4		3.6	V
$f_{SD18}$	Modulator sample frequency, ADC_CK		125	250	1000	KHz
	Over Sample Ratio, OSR		32		65536	
$f_{ADC\_CK}$	High Power mode	AD1HS[0]=1b	0.5		1.0	MHz
	Low Power mode	AD1HS[0]=0b	0.125		0.5	MHz

### 8.9.1. Operating Current

$T_A = 25^\circ\text{C}, V_{DD} = 3.0\text{V}, V_{DDA}=2.4\text{V}$ , unless otherwise noted

Parameter	Test Conditions	Min.	Typ.	Max.	unit
Analog Supply Current I, ADC_CK= 1000KHz, OSR=65536, AD1HS[0]=1b, $f_{DATA} = 15\text{SPS}$	VDDA=2.4V, Gain=1		250		$\mu\text{A}$
	VDDA=2.4V, Gain=128@PGA=x32		850		$\mu\text{A}$
Analog Supply Current II, ADC_CK= 250KHz, OSR=65536, AD1HS[0]=0b, $f_{DATA} = 4\text{SPS}$	VDDA=2.4V, Gain=1		120		$\mu\text{A}$
	VDDA=2.4V, Gain=128@PGA=x32		550		$\mu\text{A}$

### 8.9.2. Analog Inputs

$T_A = -40^\circ\text{C}$  to  $+85^\circ\text{C}, V_{DD} = 3.0\text{V}, V_{DDA}=2.4\text{V}, \text{PGA}*\text{Gain}=128$ , unless otherwise noted

Parameter	Test Conditions	Min.	Typ.	Max.	unit
Full-Scale Input Voltage(VINP – VINN)	$V_{REF} = V_{DDA}$ ,		$\pm 0.5 * V_{REF} / (\text{Gain} * \text{PGA})$		V
Full-Scale Input Voltage(VINP – VINN)	$V_{REF} = 1\text{V}$ ,		$\pm 0.9 * V_{REF} / (\text{Gain} * \text{PGA})$		V
Negative Signal Input (VINN)		VSSA-0.2		VDDA+0.2	V
Positive Signal Input (VINP)		VSSA-0.2		VDDA+0.2	V
Common-Mode Input Range		VSSA-0.2		VDDA+0.2	V

# HY13P53B

8-bit RISC-like Mixed Signal Microcontrollers with  
Embedded High Resolution  $\Sigma\Delta$  ADC



## 8.9.3. Performance

$T_A = -40^{\circ}\text{C}$  to  $+85^{\circ}\text{C}$ ,  $V_{DD} = 3.0\text{V}$ ,  $V_{DDA}=2.4\text{V}$ ,  $\text{PGA}*\text{Gain}=128$ , unless otherwise noted

Parameter	Test Conditions	Min.	Typ.	Max.	unit
Data Rate	ADC_CK=1000KHz, OSR=32, AD1HS [0]=1b		31,250		SPS
	ADC_CK=1000KHz, OSR=65536, AD1HS [0]=1b		15		SPS
	ADC_CK=500KHz, OSR=32, AD1HS [0]=1b		15,625		SPS
	ADC_CK=500KHz, OSR=65536, AD1HS [0]=1b		7.5		SPS
	ADC_CK=250KHz, OSR=32, AD1HS [0]=0b		7,812		SPS
	ADC_CK=250KHz, OSR=65536, AD1HS [0]=0b		3.8		SPS
Digital Filter Settling Time	Full Settling		3		Conversions
Integral Nonlinearity (INL)	Differential Input, End-Point Fit, $G = 1$ , $V_{IN}=0.9*V_R$ , $\Delta V_R=1.2V$		$\pm 30$	$\pm 100$	ppm
Input Offset Error	Gain=1,		$\pm 50$		ppm of FS
	Gain=128,		$\pm 5$		ppm of FS
Input Offset Drift	Gain=1		2		$\mu\text{V}/^{\circ}\text{C}$
	Gain=128		4		$\text{nV}/^{\circ}\text{C}$
Gain Drift	Input common voltage= $V_{DDA}$		5		$\text{ppm}/^{\circ}\text{C}$
	Input common voltage= $V_{DDA}/2$		5		$\text{ppm}/^{\circ}\text{C}$
AC power supply rejection ratio	$V_{DD}=3V\pm 100\text{mV}$ , $f_{VDD}=50\text{Hz}, 60\text{Hz} \pm 1\text{Hz}$	Gain = 1,		$>80$	dB
		Gain = 128		$>70$	dB
Common-Mode Rejection	at DC, Input Voltage= $V_{DDA}/2 \pm 0.1V$		$>75$		dB
Power-Supply Rejection	at DC, $V_{DDA}=3V\pm 100\text{mV}$ , Gain=1		60		dB
	at DC, $V_{DDA}=3V\pm 100\text{mV}$ , Gain=128		95		dB

## 8.9.4. Voltage Reference

$T_A = -40^{\circ}\text{C}$  to  $+85^{\circ}\text{C}$ ,  $V_{DD} = 3.0\text{V}$ ,  $V_{DDA}=2.4\text{V}$ ,  $\text{PGA}*\text{Gain}=128$ , unless otherwise noted

Parameter	Test Conditions	Min.	Typ.	Max.	unit
Voltage Reference Input (VREF)	$V_{REF} = \text{REFP} - \text{REFN}$			$V_{DDA}$	V
Negative Reference Input (REFN)		$V_{SS}-0.1$		$V_{DDA}/2$	V
Positive Reference Input (REFP)		$V_{DDA}/2$		$V_{DDA}+0.1$	V
Reference Voltage (V12)	$\text{IN1N}[2:0]=011\text{b}$ , $\text{REFOO}[0]=0\text{b}$ ; or $\text{VR1P}[1:0]=01\text{b}$ , or $\text{VR1N}[1:0]=01\text{b}$	1.18	1.2	1.22	V
V12 Temperature drift	$T_A=-40^{\circ}\text{C} \sim 85^{\circ}\text{C}$		50		$\text{ppm}/^{\circ}\text{C}$
V12 Voltage drift ( $V_{DDA}$ )			150		$\mu\text{V}/\text{V}$

# HY13P53B

8-bit RISC-like Mixed Signal Microcontrollers with  
Embedded High Resolution  $\Sigma\Delta$  ADC



## 8.9.5. Temperature sensor

$T_A = 25^\circ\text{C}, V_{DD} = 3.0\text{V}, V_{DDA} = 3.3\text{V}$ , unless otherwise noted

Sym.	Parameter	Test Conditions	Min.	Typ.	Max.	unit
$TC_{\text{Sensor}}$	Sensor temperature drift			178		$\mu\text{V}/^\circ\text{C}$
KT	Absolute Temperature Scale $0^\circ\text{K}$	Gain = 1, $V_{\text{REF}} = V_{\text{DDA}}/2$		-289		$^\circ\text{C}$
$TC_{\text{ERR}}$	One point calibrate error temperature	Calibration at $25^\circ\text{C}$ of $-40^\circ\text{C} \sim 85^\circ\text{C}$		$\pm 2$		$^\circ\text{C}$

## 8.10. Build-In EPROM(BIE)

$T_A = 25^\circ\text{C}, V_{DD} = 3.0\text{V}$ , unless otherwise noted

Sym.	Parameter	Test Conditions	Min.	Typ.	Max.	unit
$T_O$	Operation temperature range		0	25	40	$^\circ\text{C}$
$V_{\text{VPP-BIE}}$	Supply Voltage	ENBIE[0]=1, BIELV[0]=0		6.0	6.5	V
	Low Supply Voltage	ENBIE[0]=1, BIELV[0]=1	2.75			V
$I_{\text{BIE}}$	Operation supply current			5		mA
$V_{\text{SS}}$	Supply Voltage			0		V

當使用外部 $V_{\text{BIE}}$  電源燒錄BIE區塊時，可以透過指令一次燒錄一個字節(word)資料於BIE區塊內; BIELV[0]=0

當使用 2.75V 低壓燒錄控制電路時，則不需外接  $V_{\text{BIE}}$  電源仍可燒錄 BIE 區塊。

## 9. 修訂記錄

以下描述本文件差異較大的地方，而標點符號與字形的改變不在此描述範圍。

---

版本	頁次	變更摘要
V01	all	初版文件
V02	18	移除 VLCD 暫存器 LCDCN1 的控制位元 LCDTE
	24	修正 VLCD 規格描述
	25	新增 LVD 上下限規格描述